



DOC023.53.80040

# sc200 Controller

05/2010, Edition 1

**User Manual**

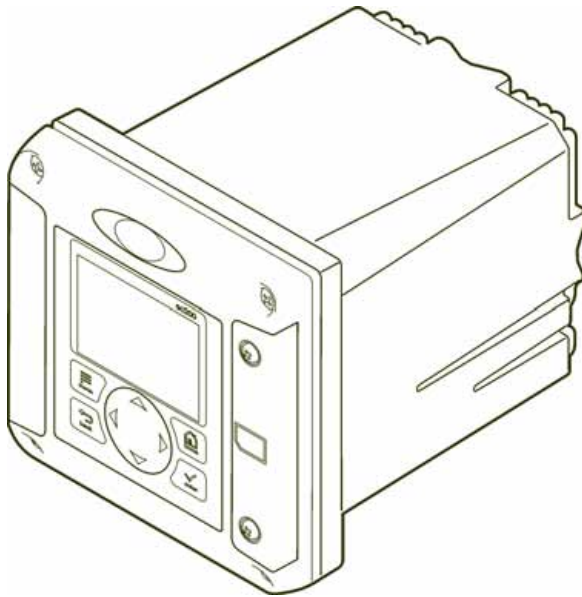



---

<b>Specifications</b>	3
<b>General Information</b>	3
Expanded manual version	3
<b>Safety information</b>	4
<b>Use of hazard information</b>	4
<b>Precautionary labels</b>	4
<b>Hach certification of compliance</b>	4
<b>Product overview</b>	5
<b>Installation</b>	6
Mounting components and dimensions	6
Controller mounting	7
High-voltage barrier	8
Electrostatic discharge (ESD) considerations	9
Wiring overview	9
Wiring for power	11
Alarms and relays	13
Wiring relays	13
Analog output connections	15
Connect a digital sc sensor	16
Connect the optional digital communication output	16
Install a Secure Digital (SD) memory card	16
<b>User interface and navigation</b>	17
User interface	17
Display	17
<b>System startup</b>	18
Set the language, date and time for the first time	18
Adjust the display contrast	19
Controller configuration information	19

## Table of Contents

---

<b>Advanced operations</b> .....	20
Security setup .....	20
Enable or disable the passcode .....	20
Edit the passcode .....	20
Configure a 4-20 mA input module .....	20
Configure a 4-20 mA output module .....	21
Configure the controller analog outputs .....	21
Logarithmic output mode .....	23
Bilinear output mode .....	23
Configure relays .....	24
Relay function graphs .....	26
Set up a calculation .....	31
Set the datalog mode and interval .....	31
Using the secure digital memory (SD) card .....	31
Saving data and event logs with SD cards .....	32
Access data and event log files on the SD card .....	33
Firmware updates with SD cards .....	33
Using the service port .....	33
Using DataCom .....	33
Update the display language .....	34
Update the date and time .....	34
<b>Maintenance</b> .....	34
Cleaning the controller .....	34
Fuse replacement .....	34
<b>Troubleshooting</b> .....	35
Test and Maintenance menu .....	36
Warning and error conditions .....	37
<b>Device scan information</b> .....	37
<b>Replacement parts and accessories</b> .....	38

## Specifications

*Specifications are subject to change without notice.*

<b>Component description</b>	Microprocessor-controlled and menu-driven controller that operates the sensor and displays measured values.
<b>Operating temperature</b>	-20 to 60 °C (-4 to 140 °F); 95% relative humidity, non-condensing with sensor load <7 W; -20 to 50 °C (-4 to 104 °F) with sensor load <28 W
<b>Storage temperature</b>	-20 to 70 °C (-4 to 158 °F); 95% relative humidity, non-condensing
<b>Enclosure</b>	NEMA 4X/IP66 metal enclosure with a corrosion-resistant finish
<b>Power requirements</b>	<p><b>AC powered sc200:</b> 100-240 VAC ±10%, 50/60 Hz; Power 50 VA with 7 W sensor/network module load, 100 VA with 28 W sensor/network module load (optional Modbus RS232/RS485 or Profibus DPV1 network connection).</p> <p><b>24 VDC powered sc200:</b> 24 VDC—15%, + 20%; Power 15 W with 7 W sensor/network module load, 40 W with 28 W sensor/network module load (optional Modbus RS232/RS485 or Profibus DPV1 network connection).</p>
<b>Altitude requirements</b>	Standard 2000m ASL (Above Sea Level)
<b>Pollution degree/ Installation category</b>	II; II
<b>Outputs</b>	Two analog (0-20 mA or 4-20 mA) outputs. Each analog output can be set to 0-20 mA or 4-20 mA, and can be assigned to represent a measured parameter such as pH, temperature, flow or calculated values. Optional 4 additional analog outputs. Maximum impedance 500 ohm. Secure Digital Memory card for use in data logging and software updates.

<b>Relays</b>	Four SPDT, user-configured contacts, rated 5A 250 VAC (resistive). Contacts are rated 250 VAC, 5 Amp resistive maximum for the AC powered sc200 and 24 VDC, 5A resistive maximum for the DC powered sc200. Relays are designed for connection to AC Mains circuits (i.e., whenever the sc200 is operated with 115 - 240 VAC power) or DC circuits (i.e., whenever the sc200 is operated with 24 VDC power).
<b>Dimensions</b>	½ DIN—144 x 144 x 180.9 mm (5.7 x 5.7 x 7.12 inches)
<b>Weight</b>	1.7 kg (3.75 lb)
<b>Compliance information</b>	CE approved (with all sensor types). Listed for use in general locations to UL and CSA safety standards by ETL (with all sensor types).
<b>Digital communication</b>	Optional Modbus RS485/RS232 or Profibus DPV1 network connection for data transmission
<b>Data logging</b>	Secure Digital Card or special RS232 cable connector for data logging and performing software updates
<b>Warranty</b>	1 year; 2 years (EU)

## General Information

In no event will the manufacturer be liable for direct, indirect, special, incidental or consequential damages resulting from any defect or omission in this manual. The manufacturer reserves the right to make changes in this manual and the products it describes at any time, without notice or obligation. Revised editions are found on the manufacturer's website.

## Expanded manual version

For additional information, refer to the CD for an expanded version of this manual.

## Safety information

Please read this entire manual before unpacking, setting up or operating this equipment. Pay attention to all danger, warning and caution statements. Failure to do so could result in serious injury to the operator or damage to the equipment.

To make sure that the protection provided by this equipment is not impaired, do not use or install this equipment in any manner other than that specified in this manual.

## Use of hazard information

### ▲ DANGER

Indicates a potentially or imminently hazardous situation which, if not avoided, will result in death or serious injury.

### ▲ WARNING

Indicates a potentially or imminently hazardous situation which, if not avoided, could result in death or serious injury.

### ▲ CAUTION

Indicates a potentially hazardous situation that may result in minor or moderate injury.

### NOTICE

Indicates a situation which, if not avoided, may cause damage to the instrument. Information that requires special emphasis.

## Precautionary labels

Read all labels and tags attached to the instrument. Personal injury or damage to the instrument could occur if not observed.



This symbol, if noted on the instrument, references the instruction manual for operation and/or safety information.



This symbol, when noted on a product enclosure or barrier, indicates that a risk of electrical shock and/or electrocution exists.



Delicate internal electronic components can be damaged by static electricity, resulting in degraded performance or eventual failure.



Electrical equipment marked with this symbol may not be disposed of in European public disposal systems after 12 August of 2005. In conformity with European local and national regulations (EU Directive 2002/98/EC), European electrical equipment users must now return old or end-of-life equipment to the Producer for disposal at no charge to the user.

**Note:** For return for recycling, please contact the equipment producer or supplier for instructions on how to return end-of-life equipment, producer-supplied electrical accessories, and all auxiliary items for proper disposal.

## Hach certification of compliance

### Canadian interference-causing equipment regulation, IECS-003, Class A

Supporting test records reside with the manufacturer. This Class A digital apparatus meets all requirements of the Canadian Interference-Causing Equipment Regulations. Cet appareil numérique de la classe A respecte toutes les exigences du Règlement sur le matériel brouilleur du Canada.

### FCC Part 15, Class "A" Limits

Supporting test records reside with the manufacturer. The device complies with Part 15 of the FCC Rules. Operation is subject to the following two conditions:

1. This device may not cause harmful interference.
2. This device must accept any interference received, including interference that may cause undesired operation.

Changes or modifications to this equipment not expressly approved by the party responsible for compliance could void the user's authority to operate the equipment. This equipment has been tested and found to comply with the limits for a Class A digital device, pursuant to Part 15 of the FCC rules.

These limits are designed to provide reasonable protection against harmful interference when the equipment is operated in a commercial environment. This equipment generates, uses, and can radiate radio frequency energy and, if not installed and used in accordance with the instruction manual, may cause harmful interference to radio communications. Operation of this equipment in a residential area is likely to cause harmful interference, in which case the user will be required to correct the interference at his own expense. The following techniques can be used to reduce interference problems:

1. Disconnect the unit from its power source to verify that it is or is not the source of the interference.
2. If the equipment is connected to the same outlet as the device experiencing interference, connect the equipment to a different outlet.
3. Move the equipment away from the device receiving the interference.
4. Reposition the receiving antenna for the device receiving the interference.
5. Try combinations of the above.

## Product overview

The controller displays sensor measurements and other data, can transmit analog and digital signals, and can interact with and control other devices through outputs and relays. Outputs, relays, sensors and sensor modules are configured and calibrated through the user interface on the front of the controller.

Figure 1 shows the product components. Components may vary according to controller configuration. Contact the manufacturer if parts are damaged or missing.

**Figure 1 System components**

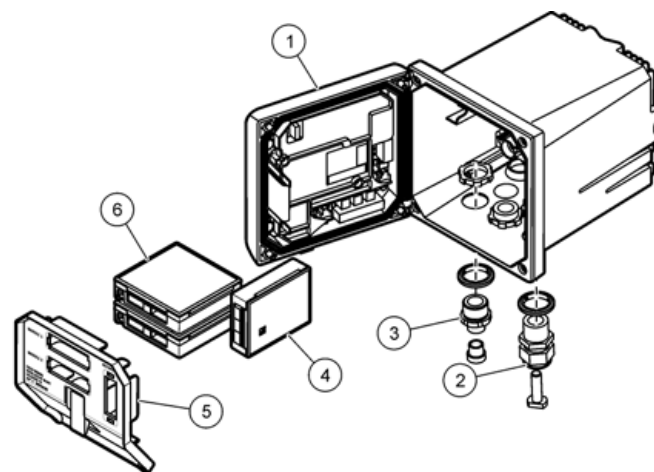

1 Controller	3 Digital connection fitting (optional depending on controller version.)	5 High-voltage barrier
2 Strain relief assembly (optional depending on controller version)	4 Network module (optional)	6 Sensor modules (optional)

### Sensors and sensor modules

The controller accepts up to a maximum of two sensor modules or two digital sensors (depending on the controller configuration), along with one communication module. A single digital sensor and a single sensor module can be installed in combination. A variety of sensors can be wired to the sensor modules. Sensor wiring information is given in the specific sensor manuals and in the user instructions for specific modules.

### Relays, outputs and signals

The controller has four configurable relay switches and two analog outputs. An optional analog output module can increase the number of analog outputs to six.

### Device scans

With two exceptions, the controller automatically scans for connected devices without user input when it is powered on. The first exception is when the controller is powered on for the first time before initial use. The second exception is after the controller configuration settings have been set to their default values and the controller is powered on. In both cases, the controller first displays the language, date and time edit screens. After the language, date and time entries are accepted, the controller performs a device scan after the language, date and time entries are accepted.

### Controller enclosure

The controller enclosure is NEMA 4X/IP66-rated and has a corrosion-resistant finish designed to withstand corrosive environmental constituents such as salt spray and hydrogen sulfide. Protection against environmental damage is strongly recommended for outdoor use.

### Controller mounting options

The controller can be mounted to a panel, to a wall or to a vertical or horizontal pipe. A neoprene sealing gasket is included and can be used to reduce vibration. The gasket can be used as a template for panel mounting before the inner gasket component is separated.

## Installation

### Mounting components and dimensions

#### ⚠ CAUTION

Personal injury hazard. Only qualified personnel should conduct the tasks described in this section of the manual.

For mounting options and instructions, refer to [Figure 2](#), [Figure 3](#), [Figure 4](#) on page 7, [Figure 5](#) on page 8 and [Figure 6](#) on page 8.

The controller can be mounted to a vertical pipe ([Figure 6](#) on page 8) or a horizontal pipe (not shown).

For horizontal pipe mounts, the mounting feet ([Figure 2](#)) must be attached to the mounting bracket in a vertical position.

For both horizontal and vertical pipe mounts, attach the mounting bracket to the controller as shown in [Figure 6](#) on page 8.

**Figure 2 Mounting components**

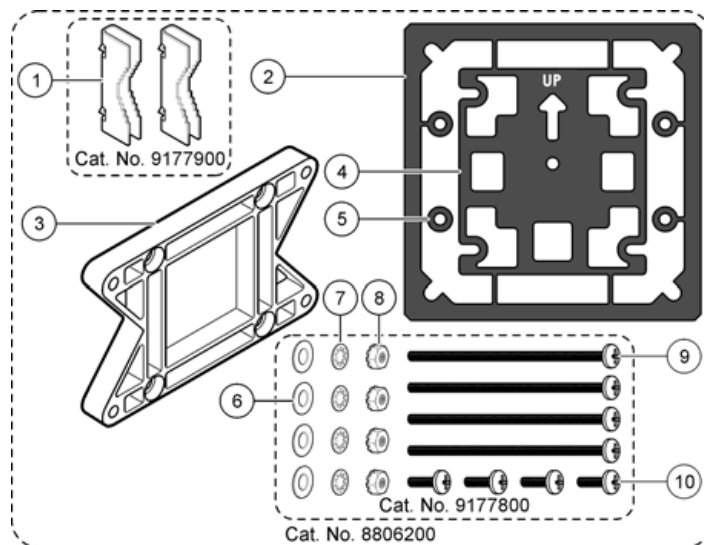

1 Mounting foot (2x)	6 Flat washer, 1/4-inch ID (4x)
2 Sealing gasket for panel mount, Neoprene	7 Lock washer, 1/4-inch ID (4x)
3 Bracket for wall and pipe mounting	8 M5 x 0.8 Keps hexnut (4x)
4 Vibration isolation gasket for pipe mount	9 Pan head screws, M5 x 0.8 x 100mm (4x) (Used for variable diameter pipe mount installations)
5 Vibration isolation washer for pipe mount (4x)	10 Pan head screws, M5 x 0.8 x 15 mm (4x)



Figure 5 Wall mount

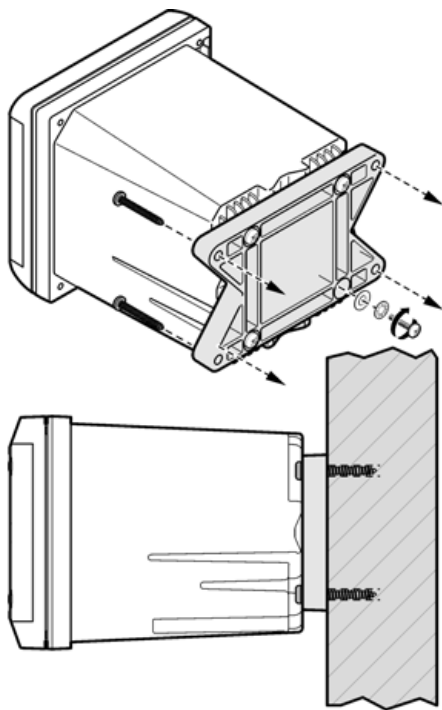
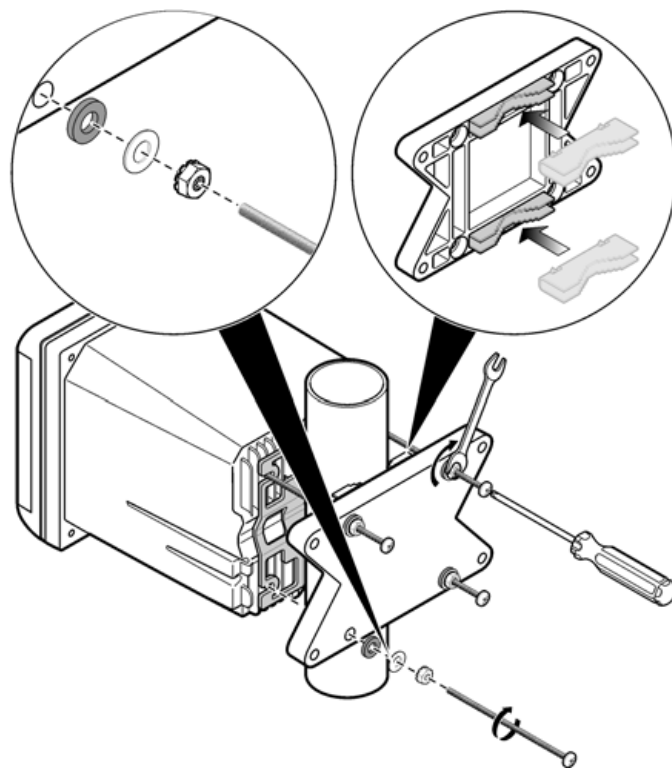

Figure 6 Pipe mount (vertical pipe)



### High-voltage barrier

High-voltage wiring for the controller is located behind the high-voltage barrier in the controller enclosure. The barrier must remain in place except when installing modules or when a qualified installation technician is wiring

for power, alarms, outputs or relays. Do not remove the barrier while power is applied to the controller.

## Electrostatic discharge (ESD) considerations

NOTICE	
	Potential Instrument Damage. Delicate internal electronic components can be damaged by static electricity, resulting in degraded performance or eventual failure.

**Note:** To minimize hazards and ESD risks, maintenance procedures not requiring power to the analyzer should be performed with the power removed from the instrument.

The manufacturer recommends taking the following steps to prevent ESD damage to the instrument:

- Before touching any instrument electronic components (such as printed circuit cards and the components on them) discharge static electricity

from your body. This can be accomplished by touching an earth-grounded metal surface such as the chassis of an instrument, or a metal conduit or pipe.

- To reduce static build-up, avoid excessive movement. Transport static-sensitive components in anti-static containers or packaging.
- To discharge static electricity from your body and keep it discharged, wear a wrist strap connected by a wire to earth ground.
- Handle all static-sensitive components in a static-safe area. If possible, use anti-static floor pads and work bench pads.

## Wiring overview

Figure 7 shows an overview of the wiring connections inside the controller with the high voltage barrier removed. The left side of the figure shows the back side of the controller cover.

**Note:** Remove connector caps from the connectors before module installation.

**Figure 7 Wiring connections overview**

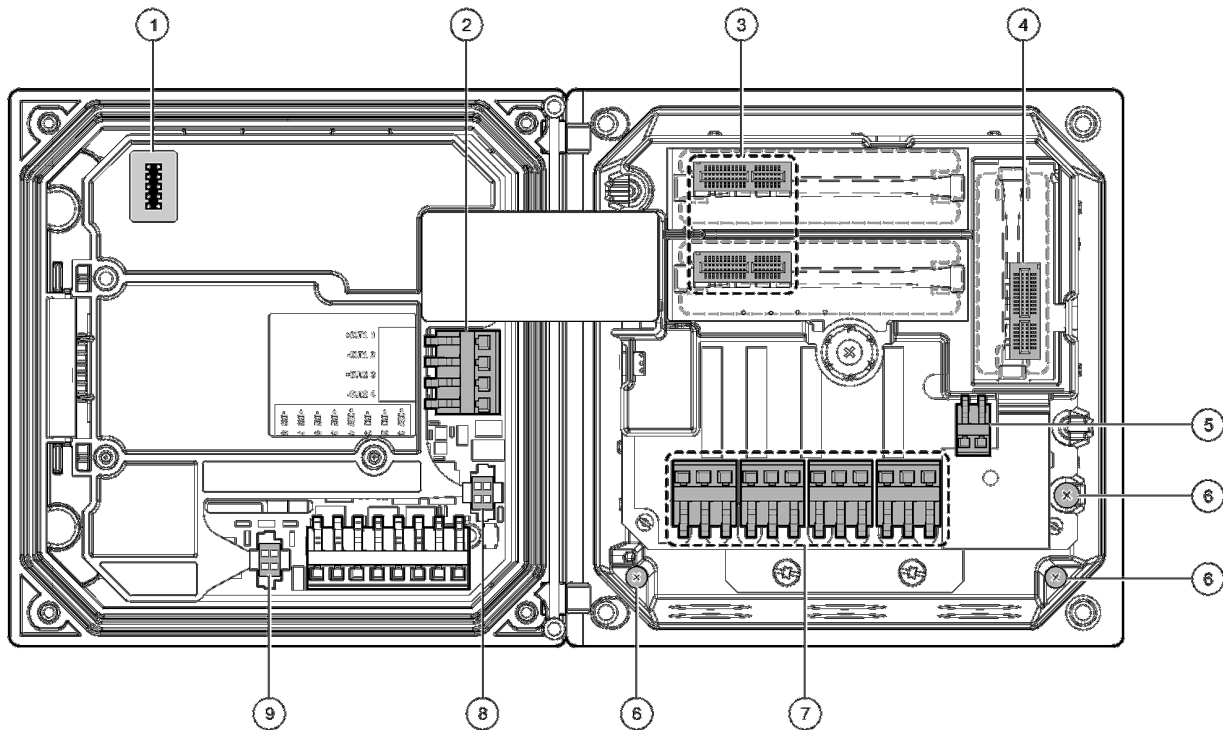

1 Service cable connection	4 Communication module connector (e.g., Modbus, Profibus, optional 4-20 mA module, etc.)	7 Relay connections
2 4-20 mA output	5 AC and DC power connector	8 Digital sensor connector
3 Sensor module connector	6 Ground terminals	9 Digital sensor connector

## Wiring for power

### ⚠ WARNING



Potential Electrocution Hazard. Always disconnect power to the instrument when making electrical connections.

### ⚠ WARNING



Potential Electrocution Hazard. If this equipment is used outdoors or in potentially wet locations, a **Ground Fault Interrupt** device must be used for connecting the equipment to its mains power source.

### ⚠ DANGER



Electrocution Hazard. Do not connect AC power to a 24 VDC powered model.

### ⚠ WARNING



Potential Electrocution Hazard. A protective earth (PE) ground connection is required for both 100-240 VAC and 24 VDC wiring applications. Failure to connect a good PE ground connection can result in shock hazards and poor performance due to electromagnetic interferences. ALWAYS connect a good PE ground to the controller terminal.

### NOTICE

Install the device in a location and position that gives easy access to the disconnect device and its operation.

The controller can be purchased as either a 100-240 VAC powered model or a 24 VDC powered model. Follow the appropriate wiring instructions for the purchased model.

The controller can be wired for line power by hard-wiring in conduit or wiring to a power cord. Regardless of the wire used, the connections are made at the same terminals. A local disconnect designed to meet local electrical code is required and must be identified for all types of installation. In hard-wired applications, the power and safety ground service drops for the instrument must be 18 to 12 AWG.

#### Notes:

- The voltage barrier must be removed before making any electrical connections. After making all connections, replace the voltage barrier before closing the controller cover.
- A sealing type strain relief and a power cord less than 3 meters (10 feet) in length with three 18-gauge conductors (including a safety ground wire) can be used to maintain the NEMA 4X/IP66 environmental rating.
- Controllers can be ordered with AC power cords pre-installed. Additional power cords may also be ordered.
- The DC power source that supplies power to the 24 VDC powered controller must maintain voltage regulation within the specified 24 VDC-15% +20% voltage limits. The DC power source must also provide adequate protection against surges and line transients.

#### Wiring procedure

Follow the numbered steps and [Table 1](#) or [Table 2](#) to wire the controller for power. Insert each wire into the appropriate terminal until the insulation is seated against the connector with no bare wire exposed. Tug gently after insertion to make a secure connection. Seal any unused openings in the controller box with conduit opening sealing plugs.

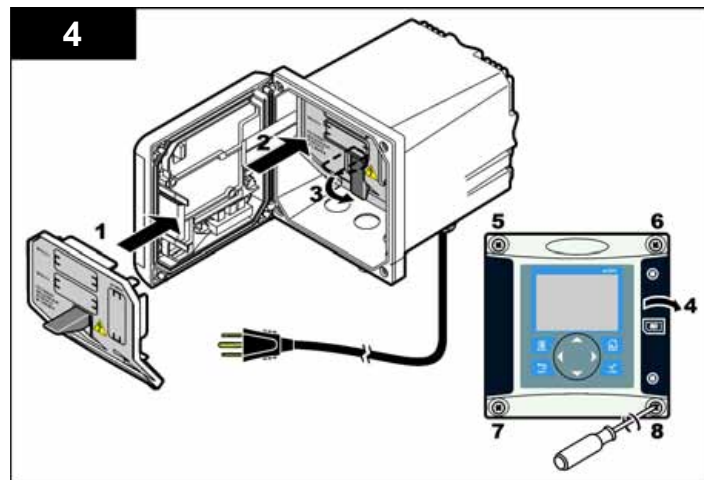
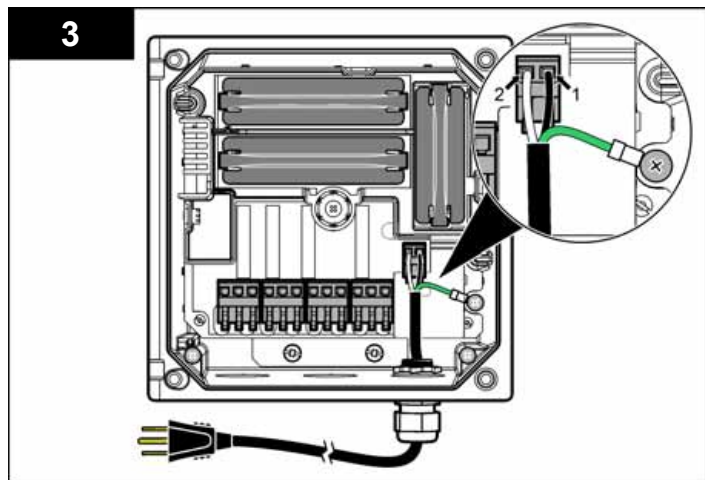
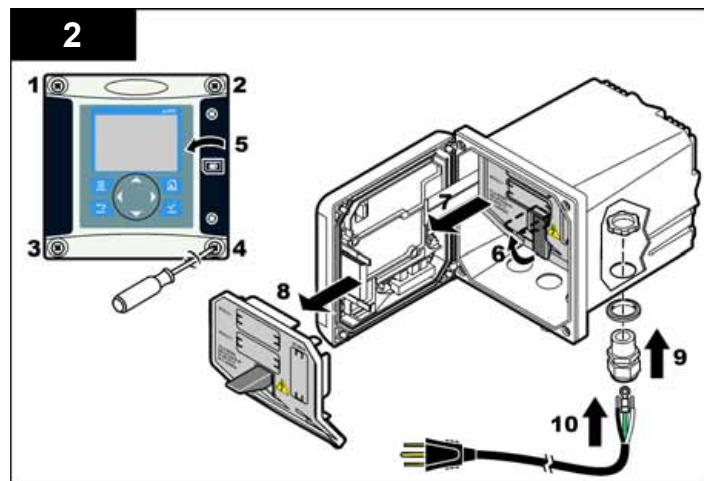
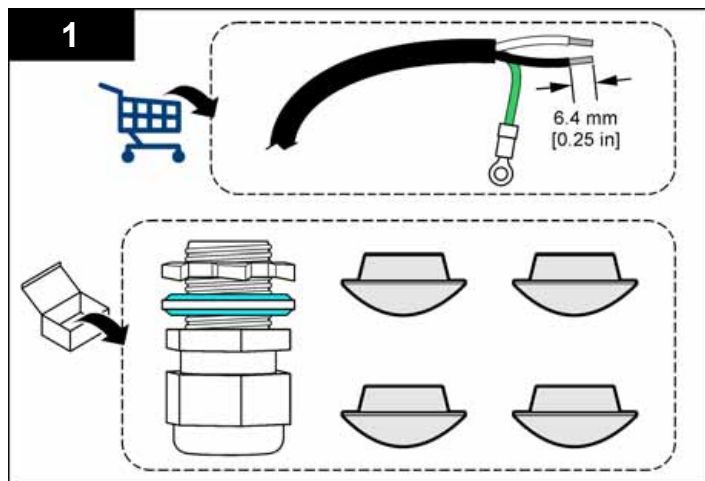

**Table 1 AC power wiring information (AC powered models only)**

Terminal number	Terminal description	Wire color code for North America	Wire color code for Europe
1	Hot (L1)	Black	Brown
2	Neutral (N)	White	Blue
—	Protective Earth (PE) Ground lug	Green	Green w/yellow stripe



**Table 2 DC power wiring information (DC powered models only)**



Terminal number	Terminal description	Wire color code for North America	Wire color code for Europe
1	+24 V dc	Red	Red
2	24 V dc return	Black	Black

## Alarms and relays

The controller is equipped with four unpowered, single pole relays rated 100-250 VAC, 50/60 Hz, 5 amp resistive maximum. Contacts are rated 250 VAC, 5 amp resistive maximum for the AC powered controller and 24 VDC, 5A resistive maximum for the DC powered controller. The relays are not rated for inductive loads.

## Wiring relays

<b>⚠ WARNING</b>	
	Potential Electrocution Hazard. Always disconnect power to the instrument when making electrical connections.
<b>⚠ WARNING</b>	
	Potential fire hazard. The relay contacts are rated 5A and are not fused. External loads connected to the relays must have current limiting devices provided to limit current to < 5 A.

<b>⚠ WARNING</b>	
	Potential fire hazard. Do not daisy-chain the common relay connections or jumper wire from the mains power connection inside the instrument.
<b>⚠ WARNING</b>	
	Potential electrocution hazard. In order to maintain the NEMA/IP environmental ratings of the enclosure, use only conduit fittings and cable glands rated for at least NEMA 4X/IP66 to route cables in to the instrument.

## AC line (100—250 V) powered controllers

The wiring compartment is not designed for voltage connections in excess of 250 VAC.

## 24 VDC powered controllers

The 24 VDC controller relays are designed for connection to LOW voltage circuits (i.e., voltages less than 30 V-RMS, 42.2 V-PEAK or 60 VDC). The wiring compartment is not designed for voltage connections above these levels.

The relay connector accepts 18-12 AWG wire (as determined by load application). Wire gauge less than 18 AWG is not recommended.

The Normally Open (NO) and Common (COM) relay contacts will be connected when an alarm or other condition is active. The Normally Closed (NC) and Common relay contacts will be connected when an alarm or other condition is inactive (unless the Fail Safe is set to Yes) or when power is removed from the controller.

Most relay connections use either the NO and COM terminals or the NC and COM terminals. The numbered installation steps show connection to the NO and COM terminals.

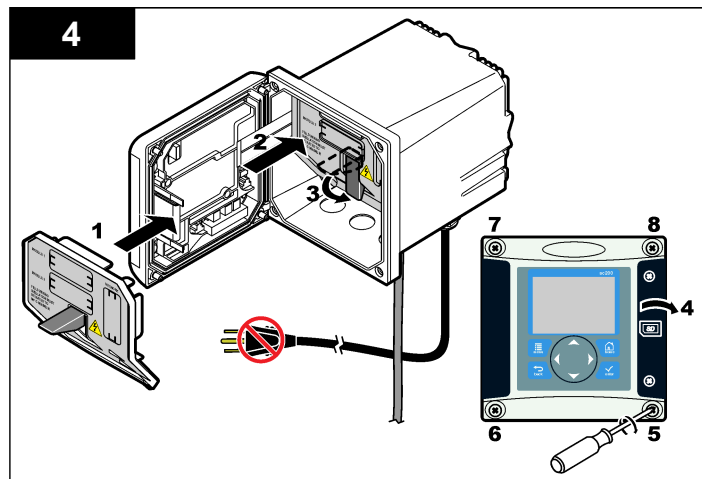
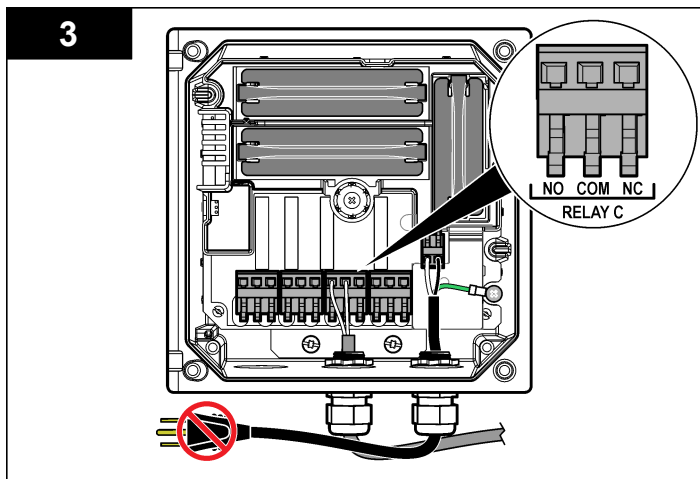
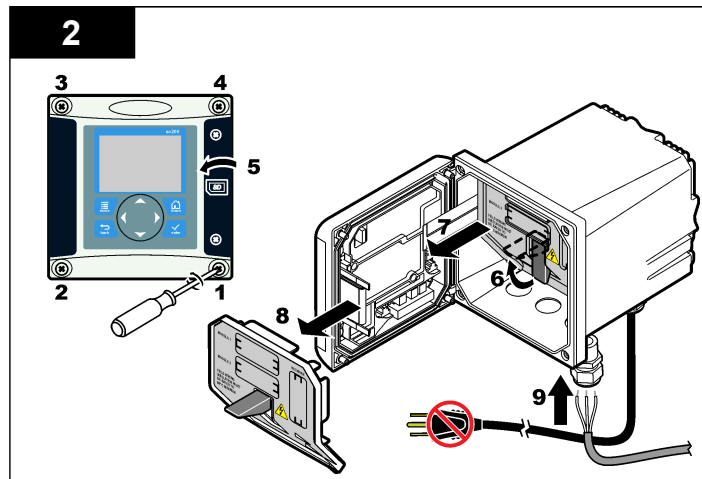
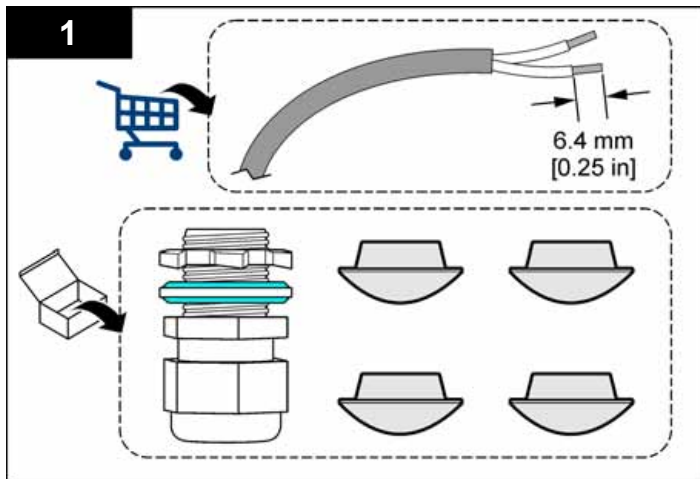

## Analog output connections

### ⚠ WARNING



Potential Electrocution Hazard. Always disconnect power to the instrument when making electrical connections.

### ⚠ WARNING



Potential electrocution hazard. In order to maintain the NEMA/IP environmental ratings of the enclosure, use only conduit fittings and cable glands rated for at least NEMA 4X/IP66 to route cables in to the instrument.

Two isolated analog outputs (1 and 2) are provided (Figure 8). Such outputs are commonly used for analog signaling or to control other external devices.

Make wiring connections to the controller as shown in Figure 8 and Table 3.

**Note:** Figure 8 shows the back of the controller cover and not the inside of the main controller compartment.

**Table 3 Output connections**

Recorder wires	Circuit board position
Output 1+	1
Output 1-	2
Output 2+	3
Output 2-	4

1. Open the controller cover.
2. Feed the wires through the strain relief.
3. Adjust the wire as necessary and tighten the strain relief.
4. Make connections with twisted-pair shielded wire and connect the shield at the controlled component end or at the control loop end.
  - Do not connect the shield at both ends of the cable.

- Use of non-shielded cable may result in radio frequency emission or susceptibility levels higher than allowed.
  - Maximum loop resistance is 500 ohm.
5. Close the controller cover and tighten the cover screws.
  6. Configure outputs in the controller.

**Figure 8 Analog output connections**

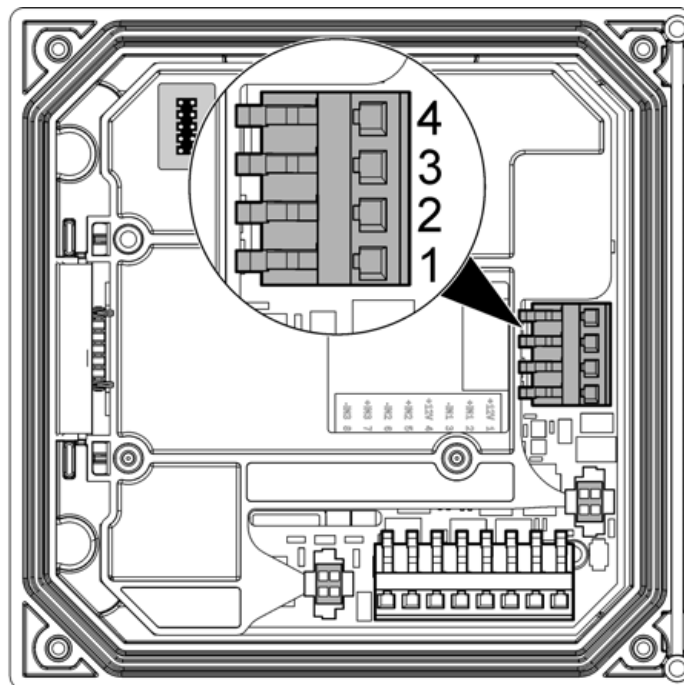

## Connect a digital sc sensor

**Note:** To connect an analog sensor, refer to the instructions supplied in the module or sensor manual.

A digital sc sensor can be connected to the controller using the keyed quick-connect fitting (Figure 9). A digital sensor can be connected with the controller powered on or off.

When a sensor is connected with the controller powered on, the controller does not automatically perform a device scan. To make the controller perform a device scan, navigate to the Test/Maintenance menu and select Scan Devices. If a new device is found, the controller performs the installation process without further user action.

When a sensor is connected with the controller powered off, the controller will perform a device scan when it is powered on again. If a new device is found, the controller performs the installation process without further user action.

Retain the connector cap to seal the connector opening in case the sensor must be removed.

Figure 9 Digital sensor quick connect

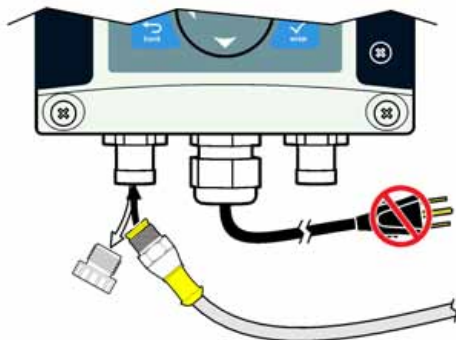

## Connect the optional digital communication output

The manufacturer supports Modbus RS485, Modbus RS232 and Profibus DPV1 communication protocols. The optional digital output module is installed in the location indicated by item 4 in Figure 7 on page 10. Refer to the instructions supplied with the network module for more details.

For information about Modbus registers, refer to <http://www.hach-lange.com> or <http://www.hach.com>.

## Install a Secure Digital (SD) memory card

For instructions on how to install an SD card in the controller, refer to Figure 10. Information on how to use the SD memory card can be found in the Using the Secure Digital memory card section.

To remove an SD card, push down on the edge of the card and release, then pull the card up and out of the slot. After the card is removed, close the slot cover and tighten the cover screws.

Figure 10 SD card installation

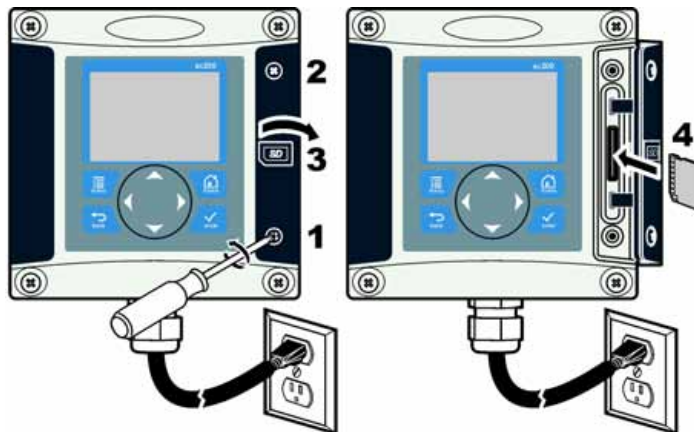

# User interface and navigation

## User interface

The keypad has four menu keys and four directional keys as shown in [Figure 11](#).

**Figure 11 Keypad and front panel overview**

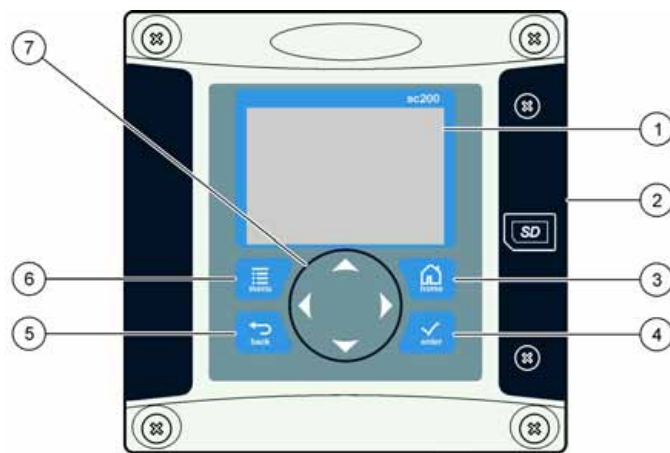

1 Instrument display	5 <b>BACK</b> key. Moves back one level in the menu structure.
2 Cover for secure digital memory card slot	6 <b>MENU</b> key. Moves to the Settings Menu from other screens and submenus.
3 <b>HOME</b> key. Moves to the Main Measurement screen from other screens and submenus.	7 Directional keys. Used to navigate through the menus, change settings, and increment or decrement digits.
4 <b>ENTER</b> key. Accepts input values, updates, or displayed menu options.	

Inputs and outputs are set up and configured through the front panel using the keypad and display screen. This user interface is used to set up and configure inputs and outputs, create log information and calculated values, and calibrate sensors. The SD interface can be used to save logs and update software.

## Reading and measurement screens

When two sensors are connected, push the **HOME** key and then push the Right or Left arrows to toggle through the available measurement display options. A combination screen is the default display mode when two sensors are connected.

Push the **UP** or **DOWN** arrows to toggle the status bar at the bottom of the measurement display. The footer bar displays controller, sensor, or network card errors and warnings; sensor and network card process events; secondary measurements and outputs.

If a menu has more options than can be displayed at one time, a scrollbar will appear on the right side of the display. Push the **UP** or **DOWN** arrows to scroll through the available menu items.

## Display

[Figure 12](#) shows an example of the main measurement screen with a DO sensor connected to the controller.

The front panel display screen shows sensor measurement data, calibration and configuration settings, errors, warnings and other information.

Figure 12 Example of Main Measurement screen

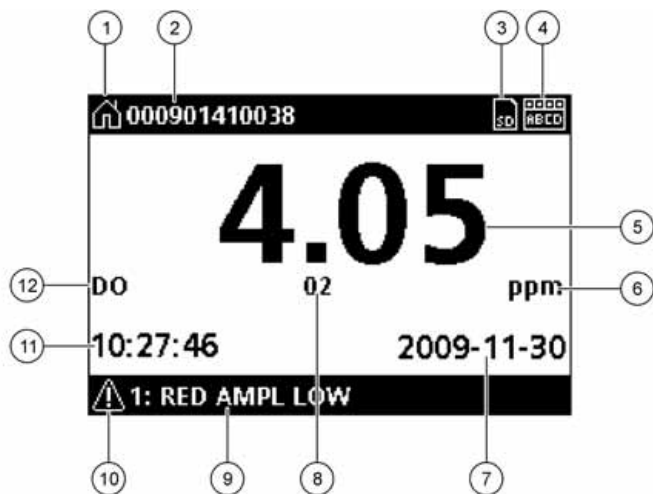

1 Home screen icon. The icon may vary depending on the screen or menu being displayed. For example, if an SD card is installed, an SD card icon appears here when the user is in the SD Card Setup menu.	7 Date
2 Sensor name	8 Measurement parameter
3 Secure Digital Memory card icon. (This icon appears only if an SD card is in the reader slot. When a user is in the SD Card Setup menu, this icon appears in the upper left corner.)	9 Display footer. Displays analog 1 and analog 2 output values, error and warning messages, and secondary measurements.
4 Relay status indicator	10 Warning icon
5 Measurement value	11 Time
6 Measurement units or warning icon (if warning exists)	12 Measurement name

### Warning icons

A warning icon consists of an exclamation point within a triangle. Warning icons appear in the display footer along with a number that indicates the associated device.

- 0=controller
- 1=sensor 1
- 2=sensor 2
- 3=network card

### Error icons

An error icon consists of an exclamation point within a circle. When an error occurs, the error icon and the measurement screen each flash again and again in the main display.

### System startup

When initially powered up, the Language, Date Format and Date/Time screens appear in order. After these options are set, the controller performs a device scan and displays the message **Scanning for devices. Please wait...** If a new device is found, the controller performs an installation process before displaying a main measurement screen.

If the scan finds previously installed devices without configuration changes, the main measurement screen of the device in the number one position appears immediately after the scan is complete.

If a device has been removed from the controller or is not found during the next power-cycled or menu-driven scan, the controller displays a **Device missing** message and prompts to delete the missing device.

If no sensor is connected to an installed analog module, the controller will indicate an error. If devices are connected but not found by the controller, refer to [Troubleshooting](#) on page 35.

### Set the language, date and time for the first time

The controller displays the language, date and time edit screens when the controller is powered on for the first time, and when it is powered on after the configuration settings have been set to their default values.

After the language, date and time options are set for the first time, update the options as necessary through the sc200 Setup menu.

1. In the Language screen, highlight a language in the options list and push the **ENTER** key. English is the default language for the controller. The selected language is saved. The Date Format screen appears.
2. In the Date Format screen, highlight a format and push the **ENTER** key. The date and time format is saved. Next, the Date /Time screen appears.
3. In the Date/Time screen, push the **RIGHT** or **LEFT** arrow keys to highlight a field, then push the **UP** and **DOWN** arrow keys to update the value in the field. Update the other fields as necessary.
4. Push the **ENTER** key. The changes are saved and the controller performs a start-up scan for devices. If connected devices are found, the controller displays the main measurement screen for the device in the number one position. If the controller fails to find connected devices, refer to [Troubleshooting](#) on page 35.

### Adjust the display contrast

1. From the Settings Menu, select sc200 Setup.
2. Select Display Contrast.
3. Use the **UP** and **DOWN** arrow keys to adjust the contrast to a value between the minimum of +1 and the maximum of +9.

### Controller configuration information

General information about configuration options is listed in the table. Step-by-step information for how to configure some of the options can be found on the CD.

1. To navigate to the menu options, from the Settings Menu, select sc200 Setup.

Option	Description
<b>Security setup</b>	Sets the passcode preferences
<b>Output setup</b>	Configures the controller analog outputs
<b>Relay setup</b>	Configures the controller relays
<b>Display contrast</b>	Adjusts the contrast of the controller display
<b>Set Date/Time</b>	Sets the controller time and date
<b>Datalog setup</b>	Configures data logging options. (Available if Calculation has been setup. At least one sensor must be attached to enter a calculation.) <ul style="list-style-type: none"> <li>• <b>Set Mode</b>—Snap shot, Average, Maximum, Minimum.</li> <li>• <b>Set Interval</b>—5 sec, 30 sec, 1 min, 2 min, 5 min, 10 min, 15 min, 30 min</li> </ul>
<b>Error Hold Mode</b>	<p><b>Hold Outputs</b>—Holds outputs at last known value when controller loses communication with the sensor.</p> <p><b>Transfer Outputs</b>—Switches to transfer mode when controller loses communication with the sensor. Outputs transfer to a pre-defined value.</p>
<b>sc200 Information</b>	<p><b>S/W VER:</b>—Displays the current version of controller software.</p> <p><b>Bootloader VER:</b>—Displays the current Bootloader version. The Bootloader is a file that loads the main operating system for the controller.</p> <p><b>S/N:</b>—Displays the controller serial number.</p>
<b>Edit name</b>	Assigns a name to the controller
<b>Language</b>	Assigns the language used in the controller

2. Select an option and push **ENTER** to activate the menu item.

## Advanced operations

### Security setup

#### Enable or disable the passcode

By default the passcode option is disabled and all configuration settings and calibrations can be changed. When the passcode function is enabled, access to Sensor calibration and Test/Maint menus requires a passcode. To enable the passcode:

1. From the Settings Menu, select sc200 Setup and push the **ENTER** key.
2. Select Security Setup and push the **ENTER** key.
3. Select Set Passcode and push the **ENTER** key.
4. Select Disabled or Enabled and push the **ENTER** key.  
The passcode is enabled.
5. Push the **BACK** key to return to the sc200 Setup Menu, or push the **MENU** key to return to the Settings Menu.

#### Edit the passcode

The passcode is factory set to SC200. The Edit Passcode menu option appears in the Security Setup menu only after the passcode feature is enabled and a valid passcode has been entered.

A passcode consists of up to six upper or lower-case alpha, numeric and special characters. Passcodes are case-sensitive.

To edit the passcode:

1. Make sure the passcode is enabled. Refer to [Enable or disable the passcode](#) on page 20 for information on how to enable the passcode.
2. From the Settings menu, select Security Setup and push **ENTER**.
3. Use the arrow keys to enter the current valid passcode and push **ENTER**.  
The Edit Passcode option appears in the Security Setup menu.
4. Select Edit Pass Code and push **ENTER**.  
The Edit Pass Code screen appears.
5. Use the arrow keys to edit the passcode and push **ENTER**.  
The new passcode is saved and the Security Setup menu appears.

**Note:** All menus stay accessible until the **HOME** key is pushed or the controller is restarted.

6. Push the **HOME** key or perform a controller restart.  
The new passcode settings are saved, and the new passcode is required to enter the Security Setup, Datalog Setup and Test/Maint menus.

### Configure a 4-20 mA input module

An analog module must be installed in the controller.

1. Determine what output the the connected device is using (0-20 mA or 4-20 mA). This information will be used to set the scale.
2. Determine what the 20 mA value is equal to (e.g, 100 psi).
3. Determine what the low end (0 or 4 mA) value is equal to (e.g., 10 psi). This information will be used to set the display range.
4. From the Settings Menu, select Sensor Setup.
5. Select Configure.
6. Update the options.
  - a. Highlight an option and push **ENTER**.
  - b. Make a selection or update the entries.
  - c. Push **ENTER** to save the changes.

Option	Description
<b>Edit name</b>	Edits the module name
<b>Edit units</b>	Edits the measurement units
<b>Edit parameter</b>	Edits the parameter name

Option	Description
<b>Display range</b> For the 0-20 mA scale:	Sets the values used for the selected scale (0-20 mA or 4-20 mA)
<ul style="list-style-type: none"> <li>• Set the 20 mA value</li> <li>• Set the 0 mA value</li> </ul>	
For the 4-20 mA scale:	
<ul style="list-style-type: none"> <li>• Set the 20 mA value</li> <li>• Set the 4 mA value</li> </ul>	
<b>Signal average</b>	Sets how often signals are averaged. Higher values produce a smoother signal but increase the time it takes for a signal to respond to a change in the process value.
<b>Set resolution—</b> X.XXX, XX.XX, XXX.X, XXXX	Sets the number of decimal places used in the display.
<b>Select scale—</b> 4-20 mA or 0-20 mA	Sets scale used for the 4-20 mA input
<b>Data log interval—</b> 5 sec, 30 sec, 1 min, 2 min, 5 min, 10 min, 15 min, 30 min, 60 min	Sets how often data is logged to the internal controller memory.
<b>Reset defaults—</b> Push <b>ENTER</b> to reset configuration settings or push the <b>BACK</b> key to cancel.	Resets configuration settings to the default values.

## Configure a 4-20 mA output module

The Network Setup option appears in the Settings Menu only if an analog output module or other network module such as Modbus or Profibus is installed in the controller.

Outputs for analog output modules are set at 4-20 mA. Outputs can be assigned to represent a measured parameter such as pH, temperature, flow or calculated values.

1. From the Settings menu, select Network Setup.
2. Select Edit Name and enter a name for the module. Push **ENTER** to save the name.
3. Select an output (A, B, C, D) and push **ENTER**.
  - a. Highlight an option and push **ENTER**.
  - b. Make a selection from the list or update the entries.
  - c. Push **ENTER** to save the changes.

Option	Description
<b>Select Source</b>	Selects the output to configure—None, sensor 1 name, sensor 2 name, calculation (if set up). For sensor output, Select Parameter sets the measurement options. When the measurement is autorange, Set Range sets the range.
<b>Set Low Value</b>	Sets the 4 mA value (default: 0.000). (Range and units depend on sensor)
<b>Set High Value</b>	Sets the 20 mA value (default: 1.000). (Range and units depend on sensor)
<b>Set Transfer</b>	Sets the transfer value. Range 3.0 to 25.0 mA (default 4.000).
<b>Set Filter</b>	Sets a time-average filter value of 0 (default) to 120 seconds.

## Configure the controller analog outputs

The controller analog outputs can be assigned to represent the measured parameter or secondary measurements such as temperature and calculations. To configure the options, highlight a menu option, push **ENTER** and select an option or update the entries. Push **ENTER** after an option is selected or the entries are updated.

1. From the Settings menu, select sc200 Setup.
2. Select Output Setup.
3. Select Output 1 or Output 2.
4. Choose Select Source and select a source from the list. Typically the source is one of the sensors attached to the system. If an analog input card is installed, the analog input may be used as a source.

5. From the Output Setup menu, choose Select Parameter and choose an option from the list. Parameters will vary depending on the type of sensors installed.
6. From the Output Setup menu, select Set Function and choose a function. Further setup options will vary depending on which function is chosen.

Option	Description
<b>Linear</b>	Signal is linearly dependent on the process value
<b>PID</b>	Signal works as a PID (Proportional, Integral, Derivative) controller
<b>Logarithmic</b>	Signal is represented logarithmically within the process variable range
<b>Bilinear</b>	Signal is represented as two linear segments within the process variable range

7. From the Output Setup menu, select Activation. Use the information in the table below the chosen function to configure the options.
8. If Transfer is or will be selected as the Error Hold Mode, or if the Transfer will be used during calibration or other functions within the sensor menu, select Set Transfer from the Output Setup menu and enter the transfer value.
9. From the Output Setup menu, select Set Filter and enter the filter value.
10. From the Output Setup menu, select Scale and choose the scale (0-20 mA or 4-20 mA).

- **Linear**

Option	Description
<b>Set low value</b>	Sets the low endpoint of the process variable range
<b>Set high value</b>	Sets the high endpoint of the process variable range

- **PID**

Option	Description
<b>Set mode (Auto or Manual)</b>	Auto—the signal is automatically controlled by the algorithm within the analyzer using proportional, integral, and derivative inputs.  Manual—the signal is controlled by the user through manual adjustment of the % change value identified in the menu as Manual Output.
<b>Phase (Direct or Reverse)</b>	The direction in which the signal responds to process change. Direct—signal increases as the process increases. Reverse—signal increases as process decreases.
<b>Set setpoint</b>	Creates a desired control point of process
<b>Prop band</b>	A function of the difference between the measured signal and the desired setpoint.
<b>Integral</b>	The period of time from the injection point of a reagent to contact with the measuring device.
<b>Derivative</b>	Used to compensate for the 2 <sup>nd</sup> order effects of the process. The majority of applications can be controlled without the use of the derivative setting.
<b>Transit time</b>	Stops all PID control for a selected period of time as the sample travels from the control pump to the measurement sensor.
• <b>Logarithmic</b>	

Option	Description
<b>Set 50% value</b>	Sets the value corresponding to 50% of the process variable range.
<b>Set high value</b>	Sets the upper value of the process variable range
• <b>Bilinear</b>	

Option	Description
<b>Set low value</b>	Sets the low endpoint value of the process variable range.
<b>Set high value</b>	Sets the high endpoint value of the process variable range.
<b>Set knee point value</b>	Sets the value at which the process variable range divides into another linear segment.
<b>Set knee point current</b>	Sets the value of the current at the knee point value.

### Logarithmic output mode

Figure 13 shows in graph form the operation of the logarithmic output mode.

Figure 13 Logarithmic output

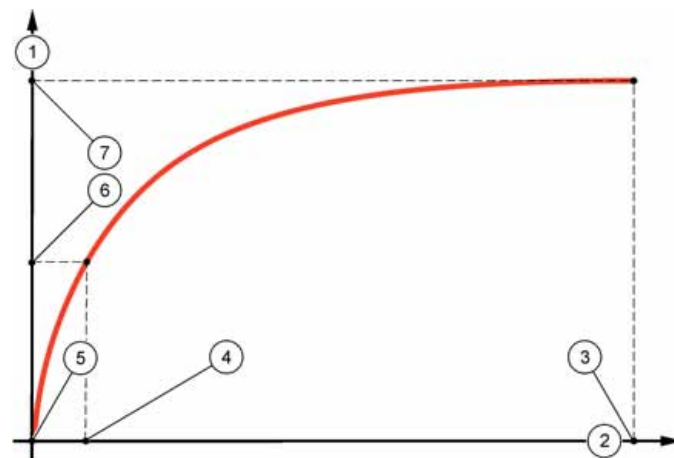

1 Output current axis	5 Minimum output current (0-4 mA)
2 Source value axis	6 50% output current
3 High value	7 Maximum output current (20 mA)
4 50% value	

### Bilinear output mode

Figure 14 shows in graph form the operation of the bilinear output mode.

**Figure 14 Bilinear output**

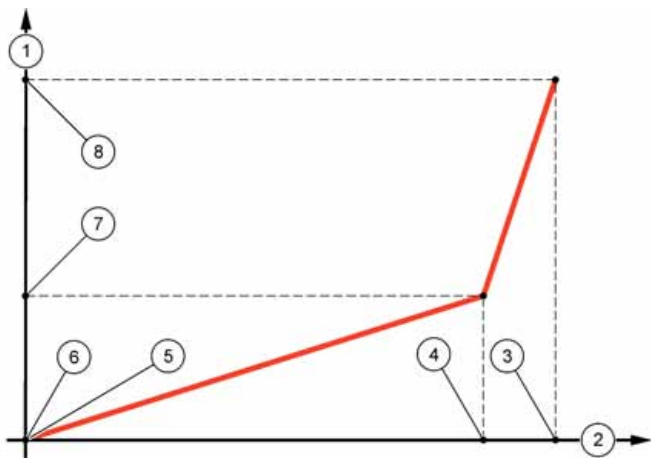

1 Output current axis	5 Low value
2 Source value axis	6 Minimum output current (0-4 mA)
3 High value	7 Knee point current
4 Knee point value	8 Maximum output current (20 mA)

## Configure relays

The Normally Open (NO) and Common (COM) relay contacts will be connected when an alarm or other condition is active. The Normally Closed (NC) and Common relay contacts will be connected when an alarm or other condition is inactive (unless the Fail Safe is set to Yes), or when power is removed from the controller. For more information about the Fail Safe option, refer to sc200 Setup. To select a menu option, highlight the option and push **ENTER**.

1. From the sc200 Setup menu, select Relay Setup.
2. Select a relay from the list.

3. From the Relay Setup menu, choose Select Source and push **ENTER**. Normally, a source is one of the sensors attached to the system, but the controller can also function as a source. If an analog input module is installed, the source may be the analog input.
4. From the Relay Setup menu, select Set Parameter and choose from the list of parameters. The list of parameter options will vary with the type of attached sensor.
5. From the Relay Setup menu, select Set Function and choose from the list. Further setup will depend on the function chosen.

Option	Description
<b>Scheduler Function</b> (available if the controller is selected as the relay source)	Relay switches at certain times independently of any process value
<b>Alarm Function</b>	Relay activates when upper or lower alarm value is exceeded
<b>Feeder Control Function</b>	Relay indicates if a process value exceeds or falls below a setpoint
<b>Event Control Function</b>	Relay toggles if a process value reaches an upper or lower limit
<b>Pulse Width Modulation (PWM) Control Function</b>	Relay uses a Pulse Width Modulation control depending on a process value
<b>Frequency control</b>	Relay switches with a frequency depending on a process value
<b>Warning</b>	Relay indicates warning and error conditions in probes

6. From the Relay Setup menu, select Set Transfer and choose Active or Inactive.
7. From the Relay Setup menu, select Fail Safe and choose Yes or No.
8. From the Relay Setup menu, select Activation. The activation options for the selected function appear. Use the information in the table below each function to update the options.

9. Test the relay function to make sure it is properly energizing the connected device. Relay testing is performed through the Test/Maint option of the Settings menu.

- **Scheduler Function**

Option	Description
<b>Hold outputs</b>	Holds outputs in the present ON or OFF state.
<b>Run days</b>	Sunday, Monday, Tuesday, Wednesday, Thursday, Friday, Saturday
<b>Start time</b>	Sets the start time
<b>Interval</b>	Sets the time between activation cycles (Default value: 5 min)
<b>Duration</b>	Sets the period of time the relay is energized (Default value: 30 sec)
<b>Off delay</b>	Sets the time for additional hold/output time after the relay has been turned off

- **Alarm function**

Option	Description
<b>Low alarm</b>	Sets the value where the relay will turn on in response to decreasing measured value. For example, if the low alarm is set for 1.0 and the measured value drops to 0.9, the relay activates.
<b>High alarm</b>	Sets the value where the relay will turn on in response to increasing measured value. For example, if the high alarm is set for 1.0 and the measured value increases to 1.1, the relay activates.
<b>Low deadband</b>	Sets the range where the relay remains on after the measured value increases above the low alarm value. For example, if the low alarm is set for 1.0 and the low deadband is set for 0.5, the relay remains on between 1.0 and 1.5. Default is 5% of the range.

Option	Description
<b>High deadband</b>	Sets the range where the relay remains on after the measured value decreases below the high alarm value. For example, if the high alarm is set for 4.0 and the high deadband is set for 0.5, the relay remains on between 3.5 and 4.0. Default is 5% of the range.
<b>Off delay</b>	Sets a time (0-300 seconds) to delay the relay from normally turning off.
<b>On delay</b>	Sets a delay time for the relay to turn on (Default: 5 seconds)

- **Feeder Function**

Option	Description
<b>Phase</b>	Defines the relay status if the process value exceeds the setpoint. High (default)—turns the relay on when the process value exceeds the setpoint. Low—turns the relay on when the process value falls below the setpoint.
<b>Set setpoint</b>	Sets the process value at which the relay toggles (Default value: 10)
<b>Deadband</b>	Sets a hysteresis so the relay will not swing unregulated when the process value converges to the setpoint.
<b>Overfeed timer</b>	Sets a time period for de-activating an active relay if the process setpoint cannot be reached. Once an overfeed alarm is present, it must be manually reset.
<b>Off delay</b>	Sets a delay time for the relay to turn off (Default: 5 seconds)
<b>On delay</b>	Sets a delay time for the relay to turn on (Default: 5 seconds)

- **Event Control**

Option	Description
<b>Set setpoint</b>	Sets the value where the relay will turn on

Option	Description
<b>Deadband</b>	Sets a hysteresis so the relay will not swing unregulated when the process value converges to the setpoint
<b>OnMax timer</b>	Sets the maximum time the relay can remain on (Default: + 0 min)
<b>OffMax timer</b>	Sets the maximum time the relay can remain off (Default: + 0 min)
<b>OnMin timer</b>	Sets the time the relay will remain on independent from the measured value (Default: + 0 min)
<b>OffMin timer</b>	Sets the time the relay will remain off independent from the measured value (Default: + 0 min)

#### • Pulse Width Modulation Function

Option	Description
<b>Set mode</b>	Auto—the relay output works as a PID controller. Manual—the relay output has an On/Off ratio as set in the Manual Output menu.
<b>Phase</b>	Reverses the leading sign of the control deviation for the PID controller (Default: Direct)
<b>Set setpoint</b>	Creates a setpoint value
<b>Dead zone</b>	A band around the setpoint. In this band the PID controller does not change the PWM On/Off ratio output signal. The dead zone is determined as the setpoint +/- the dead zone.
<b>Period</b>	Sets the cycle duration of the PWM output signal (Default: 5 seconds)
<b>Min width</b>	Sets the minimum PWM ratio (Default: 0%)
<b>Max width</b>	Sets the maximum PWM ratio (Default: 100%)
<b>Prop band</b>	Sets the proportional part of the PID controller
<b>Integral</b>	Sets the integral part of the PID controller (Default: 15 minutes)

#### • Frequency Control Function

Option	Description
<b>Set mode</b>	Auto—The relay works as a PID controller. Manual—the relay output has an On/Off ratio as set in the Manual Output menu.
<b>Phase</b>	Reverses the leading sign of the control deviation for the PID controller (Default: Direct)
<b>Set setpoint</b>	Sets the process value which is controlled by the PID controller
<b>Dead zone</b>	Band around the setpoint. In this band, the PID controller does not change the output frequency. The dead zone is determined as the setpoint +/- the dead zone.
<b>Pulse width</b>	Sets the cycle duration (0-600 seconds) of the PWM output signal. (Default: 5 seconds)
<b>Minimum pulses</b>	Sets the minimum number of pulses per minute at which the relay can operate
<b>Maximum pulses</b>	Sets the maximum number of pulses per minute at which the relay can operate
<b>Prop band</b>	Sets the proportional part of the PID controller
<b>Integral</b>	Sets the derivative part of the PID controller (Default: 15 minutes)

#### • Warning

Option	Description
<b>Warning</b>	Sets the level for warning activation

### Relay function graphs

[Figure 15](#), [Figure 16](#), [Figure 17](#), [Figure 18](#), [Figure 19](#), [Figure 20](#), [Figure 21](#), [Figure 22](#) and [Figure 23](#) show in graph form the behavior of a relay when in different function modes.

Figure 15 Alarm mode

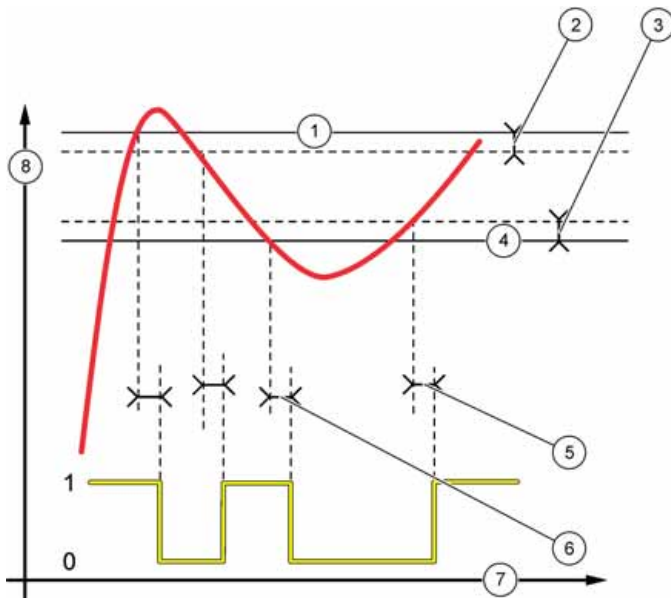

1 High alarm	5 ON delay
2 High deadband	6 OFF delay
3 Low deadband	7 Time (x-axis)
4 Low alarm	8 Source (y-axis)

Figure 16 Feeder control mode

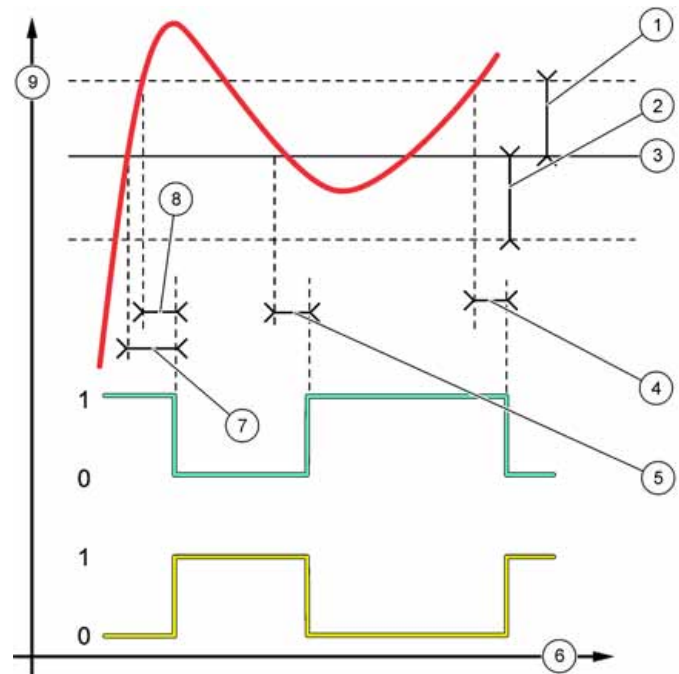

1 Deadband (Phase = Low)	6 Time (x-axis)
2 Deadband (Phase = High)	7 ON delay (phase set high)
3 setpoint	8 OFF delay (phase set low)
4 OFF delay (phase set high)	9 Source (y-axis)
5 ON delay (phase set low)	

Figure 17 Feeder control mode (Phase low, Overfeed timer)

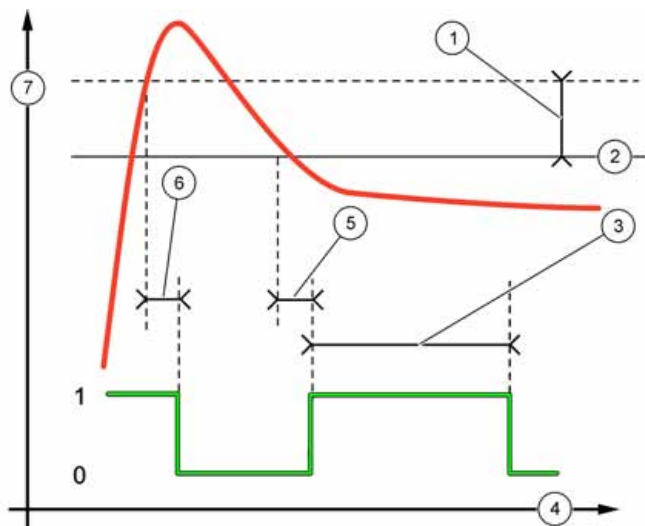

1 Deadband	5 ON delay
2 setpoint	6 OFF delay
3 Overfeed timer	7 Source (y-axis)
4 Time (x-axis)	

Figure 18 Event control mode (no delay)

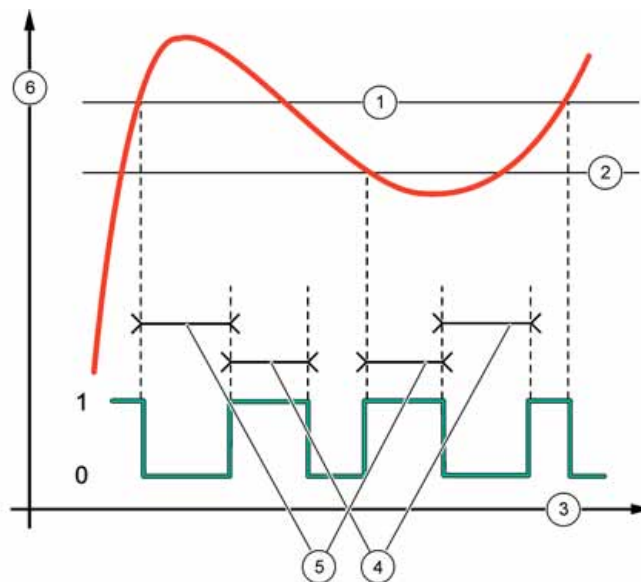

1 High alarm	4 OnMax-time
2 Low alarm	5 OffMax-time
3 Time (x-axis)	6 Source (y-axis)

Figure 19 Event control mode (OnMin timer, OffMin timer)

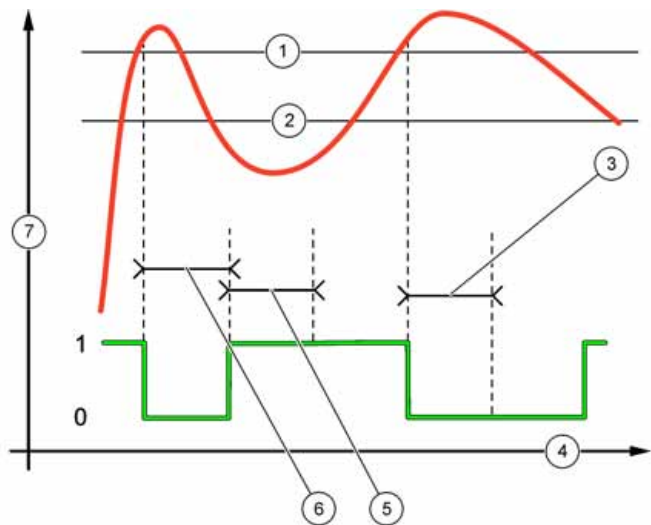

1 High alarm	5 OnMin timer
2 Low alarm	6 OffMin timer
3 OffMin timer	7 Source (y-axis)
4 Time (x-axis)	

Figure 20 Event control mode (ON/OFF delay)

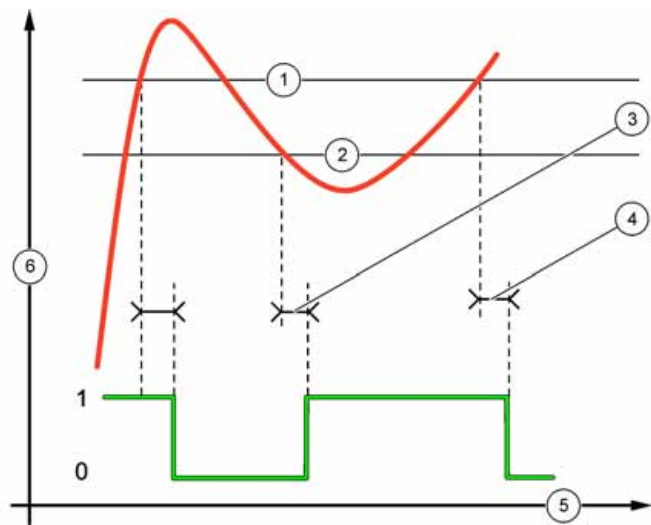

1 High alarm	4 OFF delay
2 Low alarm	5 Time (x-axis)
3 ON delay	6 Source (y-axis)

Figure 21 Pulse Width Modulation control (linear mode)

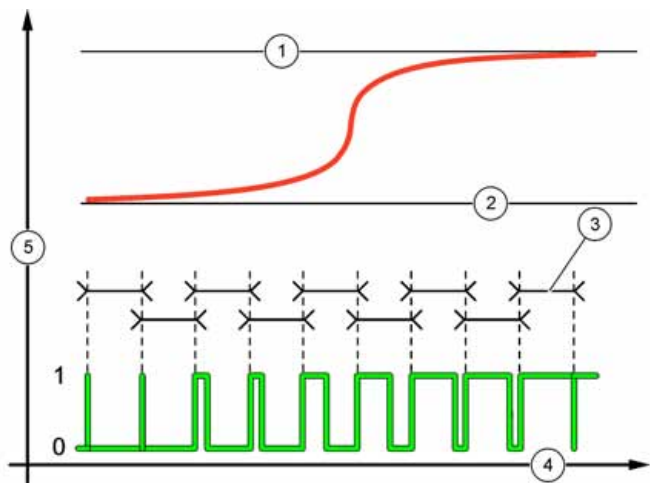

1 High alarm	4 Time (x-axis)
2 Low alarm	5 Selected source (y-axis)
3 Period	

Figure 22 Frequency control mode

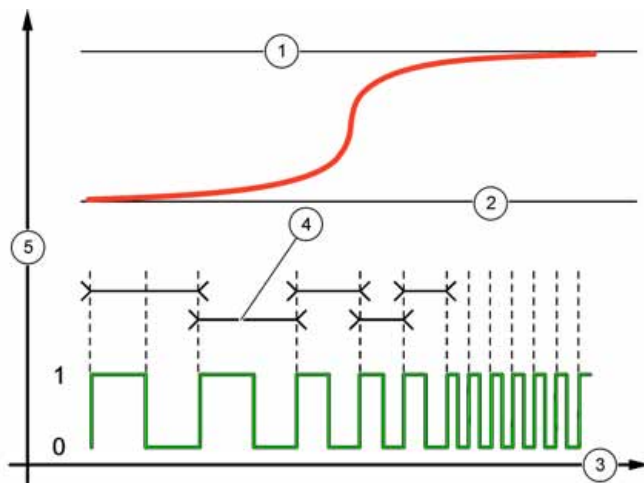

1 High limit	4 Cycle duration
2 Low limit	5 Selected source (y-axis)
3 Time (x-axis)	

**Figure 23 Relay timer mode**

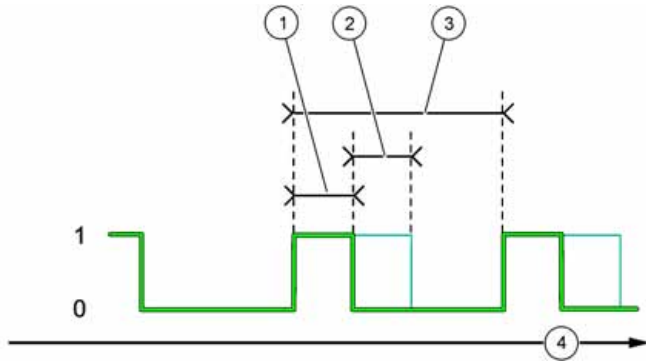

1 Duration	3 Interval
2 OFF delay	4 Time (x-axis)

### Set up a calculation

Two sensors (digital sensors or sensor modules) must be installed in the controller.

1. From the sc200 Setup menu, select Calculation and push **ENTER**. The calculation menu options appear.
2. Select a menu option and choose from the displayed list or update the entry. Refer to the table below for more information about each option.
3. Push **ENTER** to save the selection or setting and return to the Calculation menu.
4. Push the **HOME** key, **MENU** key or the **BACK** key to exit to other menus.

Option	Description
<b>Set variable X</b>	Selects the sensor that corresponds to the variable set as "X"

Option	Description
<b>Set parameter X</b>	Selects the measurement type that corresponds to the variable set as "X"
<b>Set variable Y</b>	Selects the sensor that corresponds to the variable set as "Y"
<b>Set parameter Y</b>	Selects the measurement type that corresponds to the variable set as "Y"
<b>Set formula</b>	None, X-Y, X/Y, [X/Y]%, [X+Y]/2, X*Y, [X-Y]/X
<b>Display format</b>	Sets the number of decimal places displayed in a calculation result
<b>Set units</b>	Sets the units of measurement
<b>Set parameter</b>	Assigns the name of the measurement

### Set the datalog mode and interval

Datalog Setup is available if a calculation has been set up.

1. From the Settings menu, select sc200 Setup and push **ENTER**.
2. Select Datalog Setup and push **ENTER**.
3. Select Set Mode and push **ENTER**.
4. Select an option (Snap Shot, Average, Maximum, Minimum) and push **ENTER**.
5. From the Datalog Setup menu, select Set Interval and push **ENTER**.
6. Select an interval from the list and push **ENTER**.

### Using the secure digital memory (SD) card

An SD card must be installed in the controller.

- The SD card can be used to update software and firmware and to download event and data logs. If the SD card is installed while the controller is in the Settings Menu, push the **HOME** key and then the **MENU** key to verify the option is visible. The SD icon will also be visible in the upper status bar of the main measurement screen when a card is installed.

- Data log files on the SD card are available in XML and binary formats.
- DataCom is used to convert files from binary to CSV format. Refer to the DataCom manual for more information on how to use the application. The DataCom manual, software updates and other downloadable resources are available at <http://www.hach.com/download-resources>.

## Updating software

### Notes:

- The controller does not automatically transfer information to or from an SD card.
  - Each controller will have an associated folder on the SD system. To make sure software updates are in the correct folder for the controller in use, it is best to use a separate dedicated SD card for each controller.
1. From the Settings Menu, select SD Card Setup and push the **ENTER** key.
  2. Select Upgrade Software and push the **ENTER** key.
  3. Select a device from the list and push the **ENTER** key. The list of options includes the controller and all connected devices that have software placed in the appropriate folder on the SD card.
  4. If more than one version of the upgrade software is available, select a version and push the **ENTER** key.
  5. Push the **ENTER** key to begin the software transfer. The display will show "Transferring files. Please wait..." The percentage of completion appears in the bottom left corner of the display. The upgrade cannot be halted once it has begun.
    - When the transfer is successful, the display will show "Transfer complete" along with a prompt to push **ENTER** to restart the controller or to push the **BACK** key and exit to the SD Card Setup menu. Controller updates take effect when the controller is restarted. A restart is not necessary for sensor updates.
    - If the transfer is unsuccessful, the display will show "Transfer failed" and an error message. Press the **ENTER** key to acknowledge the warning and exit out of the menu.

## Saving data and event logs with SD cards

### Notes:

- Data and event logs can be downloaded to an SD card and viewed with any device capable of reading an SD card.
- Data logs store the measurement data at selected intervals in a packed binary format (.fig file).
- Event logs store a variety of events that occur on the devices such as configuration changes, alarms and warning conditions. Event logs are set up during the sensor or module configuration process. Event logs are stored in a CSV format.

1. From the Settings Menu, select SD Card Setup and push the **ENTER** key.
2. Select Save Logs and push the **ENTER** key.
3. If more than one device appears on the screen, all devices are selected by default. To deselect an item, highlight the selection and push the left arrow key. Select the devices from which logs will be saved and push the **ENTER** key.
4. Select the time period from which logs are to be saved.

Option	Description
<b>Last Day</b>	All logs from the last full 24 hours, starting from 12:00 a.m., and any additional time remaining on the current day
<b>Last Week</b>	All logs from the last full week (7 days) starting from 12:00 a.m., and any additional time remaining on the current day
<b>Last Month</b>	All logs from the last full month (30 days) starting from 12:00 a.m., and any additional time remaining on the current day
<b>All</b>	Save all logs in memory
<b>New</b>	All logs that are new since the last time logs were saved to the SD card

5. Push the **ENTER** key to confirm the choice, and push the **ENTER** key again to begin the file transfers.
6. Allow time for the files to transfer. The display will show Transferring files. Please wait... and the percentage of files transferred.

If the transfer is successful, the display will show "Transfer complete."  
If the transfer is not successful, the display will show "Transfer failed."

7. Do one of the following:
  - a. Push the **ENTER** key to exit back to the SD Card Setup menu.
  - b. Push the **HOME** key to return to the measurement screen.
  - c. Push the **BACK** keys to return to the Settings Menu.

## Access data and event log files on the SD card

A PC, a USB or other SD card reader device, Excel 2003 or higher (for XML files) or the Data Com application (for binary flg files) are necessary to view the event and data logs stored on an SD card.

Data logs have the following structure: Device Name, Device Serial Number, Device Identification, Data Log, Time Stamp.

Event logs have the following structure: Device Name, Device Serial Number, Device Identification, Event Log, Time Stamp.

To view data or event log files stored on the SD card:

1. Attach the card reader device to the PC and install the SD card that contains the files in the reader device.
2. In the SD card directory, open the HACH folder.
3. Select the Logs folder.
4. Select a device folder.  
The event and data log files in the folder are shown.
5. To view XML data log files:
  - a. Make sure the HachDatalog.xsl style sheet exists in the device folder.
  - b. Open the Excel application.
  - c. Go to File, Open.
  - d. Select the data log file.
  - e. In the Import XML dialog box, select **Open the file with the following style sheet applied** and select **HachDatalog.xml**.
  - f. Click OK to view the data.
6. To view binary data log (.flg) files:

- a. Make sure the device driver (.flg.drv) file exists in the device folder.
- b. Open Data Com.
- c. In the File Viewer section, click Open.
- d. Select the data log file.  
The data log file is shown in the box and a comma separated values (csv) file with the same file name is created. This csv file can be opened in Excel.

## Firmware updates with SD cards

The latest firmware updates can be placed on an SD card. The SD card can then be used to update the controller or device firmware.

A PC and a USB card reader or other device capable of reading an SD card are necessary.

1. Attach the card reader device to the PC and install the SD card in the device.
2. In the directory of the SD card, open the HACH folder.
3. Select the Firmware folder.  
The list of device folders is shown. If a device is not in the folder list, install the SD card in a controller that has the device installed. The controller will create the device folder in the Firmware folder.
4. Move or copy the latest firmware files from their source to the correct device folder. The latest firmware can be found at <http://www.hach.com/scsoftware>.
5. Remove the SD card and follow the instructions in this manual to update the controller and device firmware.

## Using the service port

The service port is used to download data files from the controller. To download data and update software, use the service port in combination with DataCom and a service cable (LZX887). The service port can also be used to update controller and sensor firmware.

## Using DataCom

When using the service port, it is necessary to use DataCom. DataCom is a PC Application Utility that downloads data log and event log files from

the controller and installed sensors. Files are downloaded from the controller through the controller service port or they can be placed on a Secure Digital Memory (SD) card installed in the controller. In addition, DataCom is used to upload software for the controller and sensors. The DataCom application must be installed on a PC to read the files.

Refer to the DataCom manual for more information on how to use the application. The DataCom manual, software updates and other downloadable resources are available at <http://www.hach.com/download/resources>.

## Update the display language

The display language can be changed through the Setup menu.

1. From the Settings Menu, select sc200 Setup and push **ENTER**.
2. Select Language and push **ENTER**.  
The list of language options appears. English is the default language for the controller.
3. Highlight the language to be used for the controller and push **ENTER**.  
The selected language is saved and is used for the controller display. The display returns to the sc200 Setup menu.

## Update the date and time

The date and time settings can be changed through the Setup menu.

1. From the Settings menu, select sc200 Setup and push **ENTER**.
2. Select Set Date/Time and push **ENTER**.
3. Select Date Format from the Set Date/Time screen and push **ENTER**.
4. Select a format and push **ENTER**.
5. Select Date/Time from the Set Date/Time screen and push **ENTER**.
6. Update the entries.
  - a. Use the right and left arrow keys to highlight a field.
  - b. Use the up and down arrow keys to change the values in the field and push **ENTER**.

- c. At the end of the date field, push the right arrow to wrap down to the time fields.
  - d. Use the up and down and arrow keys to update the time fields.
7. Push **ENTER** to save the changes.  
The controller returns to the Set Date/Time menu.

## Maintenance

### ⚠ CAUTION

Personal injury hazard. Only qualified personnel should conduct the tasks described in this section of the manual.

## Cleaning the controller

### ⚠ CAUTION

Personal injury hazard. Only qualified personnel should conduct the tasks described in this section of the manual.

### ⚠ DANGER



Always remove power from the controller before performing maintenance activities.

**Note:** Never use flammable or corrosive solvents to clean any part of the controller. Use of these solvents may degrade the environmental protection of the unit and may void the warranty.

1. Make sure the controller cover is securely closed.
2. Wipe the controller exterior with a cloth dampened with water, or with a mixture of water and mild detergent.

## Fuse replacement

Fuses are not user-serviceable items. The need for fuse replacement in controllers indicates severe technical failure and is therefore considered to be a service activity. If a blown fuse is suspected, contact Hach Technical Support.

## Troubleshooting

Problem	Resolution
No current output	Verify current output configuration.
	Test current output signal using the Test/ Maintenance submenu. Input a current value and verify the output signal at the controller connections.
	Contact Hach Technical Support.
Incorrect current output	Verify current output configuration.
	Test current output signal using the Test/ Maintenance submenu. Input a current value and verify the output signal at the controller connections. If the output is incorrect, perform an output calibration.
No relay activation	Make sure relay connections are secure.
	If using an external power source, make sure the relay wiring is correct.
	Make sure the relay configuration is correct.
	Test the relay activation through the Test/ Maintenance menu. The relay should energize and de-energize as selected.
	Make sure the controller is not in calibration mode and that the relay is not being held.
	Reset the Overfeed Timer to make sure the timer has not expired.

Problem	Resolution
Secure Digital Memory (SD) card not recognized by the controller	Make sure the SD card is properly oriented. The copper traces should face toward the controller display.
	Make sure the SD card is fully seated in the slot and the spring lock is engaged.
	Make sure the SD card is properly formatted with a Fat 32 format. The MMC format is not supported. Follow the instructions of the card manufacturer to format the SD card on a PC.
	Make sure the card is not larger than 32 GB.
Information not saving, or not saving properly to the SD card.	Make sure an SD card is being used. Other types of cards (such as xSD, micro SD, mini SD) will not work properly.
	Make sure the SD card is properly formatted with the FAT 32 format. The MMC format is not supported. Follow the instructions of the card manufacturer to format the SD card on a PC.
	If the SD card has previously been in use, format the card with the Fat 32 format, install the card in the controller, and try downloading files.
SD card full	Try a different SD card.
	Read the SD card with a PC or other card reader device. Save important files and then delete some or all of the files on the SD card.

Problem	Resolution
Controller cannot find software updates on the SD card.	Make sure an appropriate folder is created by installing the SD card in the sc200. An update folder will automatically be created.
	Install the SD card on a PC and make sure the software files are located in the appropriate update folder.
	If the same SD card is used with multiple controllers, each controller will have a separate folder on the system. Make sure the software updates are in the folder dedicated to the controller in use.
Display is lit but shows no characters or characters are faint or blurry.	Adjust the display contrast
	Make sure protective film has been removed from display.
	Clean the outside of the controller, including the display screen.
Controller will not power up, or powers up intermittently	Make sure the AC power connections are properly terminated in the controller.
	Make sure the power strip, line power, wall plug are all properly plugged in.
	Contact Hach Technical Support
Network or sensor module not recognized	Make sure the module is properly installed.
	Make sure the module selector switch is set to the proper number.
	Remove sensor module and install the module into the second analog slot. Apply power to the controller and allow the controller to perform a device scan.
	Contact Hach Technical Support.

Problem	Resolution
Sensor not recognized	If the sensor is an analog sensor and a corresponding module is installed in the controller, refer to the instructions supplied with the Network or Sensor Module.
	Make sure the digital connector wiring harness is seated on the inside of the door assembly and that the wiring harness is not damaged.
	If the digital sensor is connected to the controller with a digital termination box, user supplied junction box, digital extension cables, or a user-supplied extension cable, connect the sensor directly to the controller and perform a device scan. If the controller recognizes the sensor, check that all the wiring in the junction boxes or extension cables is correct.
	Make sure that only two sensors are installed in the controller. Although two analog module ports are available, if a digital sensor and two analog modules are installed, only two of the three devices will be seen by the controller.
	Contact Hach Technical Support
Device Missing error message appears	Perform a Device Scan from the Test/ Maintenance menu.
	Power cycle the controller

## Test and Maintenance menu

- From the Settings Menu, select Test/Maint and push **ENTER**.

Option	Description
Scan devices	Performs a scan for active and missing devices.

Option	Description
<b>Output cal</b>	Calibrate 4 mA output (Min: 0 Max: 25000)
<ul style="list-style-type: none"> <li>• <b>Output 1</b></li> <li>• <b>Output 2</b></li> </ul>	Calibrate 20 mA output (Min: 35000 Max: 65533)
<b>Hold outputs</b>	Set activation—Launch or release Set Outmode—Hold Outputs (default) or Transfer Outputs Set Channels—All (default) or select from hardware list
<b>Test output</b>	Min: 0 mA (default +04.00) Max: 25.00 mA
<ul style="list-style-type: none"> <li>• <b>Output 1</b></li> <li>• <b>Output 2</b></li> </ul>	
<b>Status</b>	View status of all modules, sensors and relays.
<b>Test relay—A, B, C, D</b>	Energize or De-energize the selected relay
<b>Overfeed reset</b>	Resets the Overfeed Timer.
<b>Reset default config</b>	Resets controller configuration settings to default values
<b>Restart sc200</b>	Performs a controller restart
<b>Simulation (only displays if sensors or modules are connected)</b>	Source- <ul style="list-style-type: none"> <li>• &lt;Module 1&gt;</li> <li>• &lt;Module 2&gt;</li> </ul> <p>(Footer displays current source selection)</p> <p>Parameter—Source measurement type (footer displays current source selection)</p> <p>Sim value—Use arrow keys to change value (footer displays current source selection)</p>

Option	Description
<b>Modbus stats</b>	Displays Error and Good count stats for selected port. <ul style="list-style-type: none"> <li>• Sensor port 1, 2, 3 or 4</li> <li>• Network port</li> <li>• Service port</li> <li>• Clear stats</li> </ul>
<b>System data</b>	Displays the current system current, temperature and voltage data.

## Warning and error conditions

Follow the steps below to acknowledge controller warnings.

1. From the Settings menu, select Diagnostics and push **ENTER**.
2. Select the device (controller, sensor, network card) with the warning or error and push **ENTER**.
3. Select the warning, error or event list and push **ENTER**.
4. Select Yes and push **ENTER** to acknowledge the warning.  
*Note: Errors cannot be acknowledged.*
5. For more information on a specific warning, error or event, refer to the device manual.

## Device scan information

Display message	Action
Installing device...please wait	The controller has found a new device. No action is necessary. The controller automatically performs an installation process for the new device and displays the main measurement screen of the device installed in the number one position.

Display message	Action
Device missing <device id>	<p>A previously installed device has been removed from the controller or is not detected.</p> <ul style="list-style-type: none"> <li>• Push the <b>Enter</b> key to continue.</li> <li>• Push the left arrow key to select or de-select a missing device.</li> <li>• Push the <b>Enter</b> key to delete the missing device.</li> </ul> <p>The controller will display the main measurement screen for the device in the number one position.</p> <p><i>Note: This message also displays when a device is missing and a new device has been installed. After the missing device is deleted, the controller automatically installs the new device and displays Installing device...please wait. The controller then displays the main measurement screen for the device installed in the number one position.</i></p>

## Replacement parts and accessories

Description	Item number
1 GB Secure Digital Memory (SD) card	LZY520
Connector for digital sensor	9178100
Controller installation kit	8806200
DataCom cable	LZX887
Manual CD	DOC083.98.80040
Mounting bracket inserts	9177900
Plug, conduit opening	5868700
Power cord, with strain relief, 125 VAC	5448800

Description	Item number
Power cord, with strain relief, 230 VAC, European-style plug	5448900
Screw driver	6134300
SD card reader	LZY522
SD card cover for sc200 controller	8787100
Spare screws for controller installation kit	9177800
Strain relief assembly, Heyco	9178000
Sealing washer	1033814
Sun screen	8809200
Sun shield (metal)	1000G3088-001
Sun shield (plastic)	LZX961.54
<b>Sensor and communication modules</b>	
Conductivity module	9013000
Flow module	9012700
4-20 mA input module	8782600
4-20 mA output module	8783600
pH and DO module	9012900
Modbus network module	9013200
Profibus network module	YAB104
Profibus M12 connector kit	9178500
Profibus M12 socket Profibus	9178200
Profibus M12 straight plug	9178300
Profibus M12 T plug	9178400



**HACH COMPANY World Headquarters**

P.O. Box 389, Loveland, CO 80539-0389 U.S.A.  
Tel. (970) 669-3050  
(800) 227-4224 (U.S.A. only)  
Fax (970) 669-2932  
orders@hach.com  
www.hach.com

**HACH LANGE GMBH**

Willstätterstraße 11  
D-40549 Düsseldorf  
Tel. +49 (0) 2 11 52 88-320  
Fax +49 (0) 2 11 52 88-210  
info@hach-lange.de  
www.hach-lange.de

**HACH LANGE Sàrl**

6, route de Compois  
1222 Vézenaz  
SWITZERLAND  
Tel. +41 22 594 6400  
Fax +41 22 594 6499

